

IDD Process & Packaging, Inc.

Design - Manufacture - Installation of Process & Packaging Systems

HEBS **High Efficiency Brewing System**

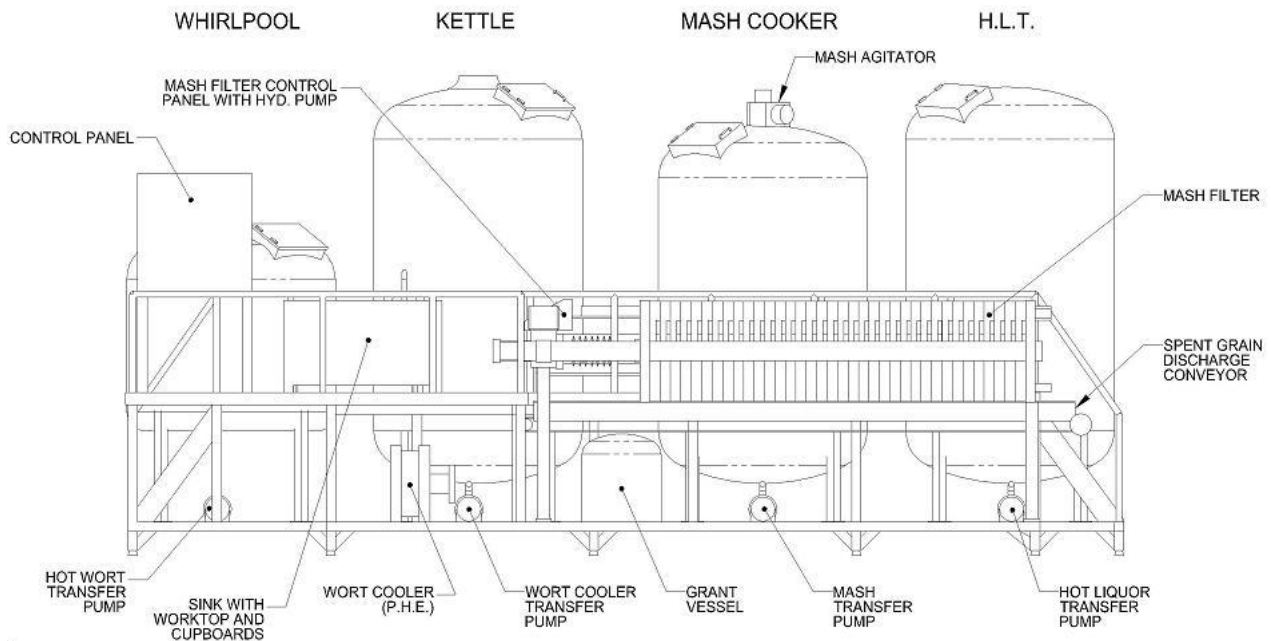

- Many existing "standard" 2-vessel Brewhouse systems are upgradable
- A mash filter sized for the craft brewing industry
- 98% plus extract – up by 10% or more compared to the best Lauter Tuns.
- 20% less water usage than a Lauter Tun
- 65% spent grain solids – up by 25% or more compared to a Lauter Tun
- 10% or more savings in raw materials
- Reduced starch conversion time
- Ability to use any starch as a source of fermentable...gluten free, grains, cookies and cereals
- Less than a 2 hour turnaround time between brews
- Feed and return piping in 304 stainless steel with tri-clamp connections
- Double diaphragm pump for mash transfer
- Mash filter plates are FDA-GRAS polypropylene in a mixed pack format
- The hydraulic pneumatically operated pump system uses vegetable oil



Contact:

5450 Tech Circle, Moorpark, CA 93021
Tel: 805-529-9890, Fax: 805-529-9282
Toll Free: 800-621-4144
Email: idd2jeff@aol.com
Web Site: www.iddeas.com